

# PTP 1510 bandsaw



## Technical details of the header:

Saw lead wheels	1510 mm
Wheel width	190 mm
Band	206/10500 mm
Main engine	55, 75, 90 kW
Saw line clearance	110 cm
Header inclination angle	15°
Header mass	5500 kg

- Automatic system for saw tensioning
- Dynamic saw wheel balancing
- All line movements on bearing blocks
- Electric controls of inclination of upper wheel
- Pulsating slides pushing the saw.
- Central greasing of movable elements
- Adjustable line speed of the band



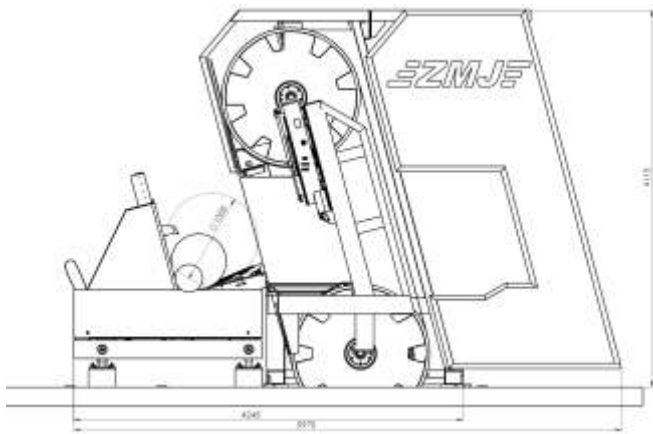

### Technical details od trolley:

- Hydraulic clamping jaws
- Max. clamp opening 800 mm
- Items hanging jaws 15/65/115/165 mm
- Speed jaws 0,5 m/s
- The thickness of the last board 25 mm
- Mass 4000 kg
- Central greasing of movable elements
- All linear movements on the bearing blocks

